

The L-INX Automation Servers LINX-100 and LINX-101 can host user specific graphical pages and can integrate physical I/Os through L-IOB I/O Modules via LIOB-FT or LIOB-IP.

The powerful Automation Servers provide connectivity functions to concurrently integrate CEA-709 (LonMark Systems), Modbus, and M-Bus subsystems. LonMark Systems can be integrated via IP-852 (Ethernet/IP) or TP/FT-10. LINX-100 Automation Servers feature an integrated Remote Network Interface (RNI) to access the TP/FT-10 channel on the device via Ethernet/IP. LINX-101 Automation Servers feature a built-in IP-852 router providing the complete feature set of the corresponding L-IP devices. In addition, the L-INX Automation Servers provide connectivity to Modbus TCP via Ethernet/IP and to Modbus RTU via RS-485. M-Bus device integration needs an optional interface module.

The gateway functionality allows data communication between all communication technologies available on the device. Different technology data points are mapped through Local Connections on the device. The mapping of different technology data points on distributed devices is supported by Global Connections. L-INX Automation Servers also support Smart Auto-Connect™ – the automatic generation of connections to substantially reduce engineering efforts and cost. All technology data points are automatically created as OPC XML-DA data points as well.

The L-INX devices provide fully featured AST™ functionality (Alarming, Scheduling, and Trending) and can be integrated perfectly into the L-WEB System.

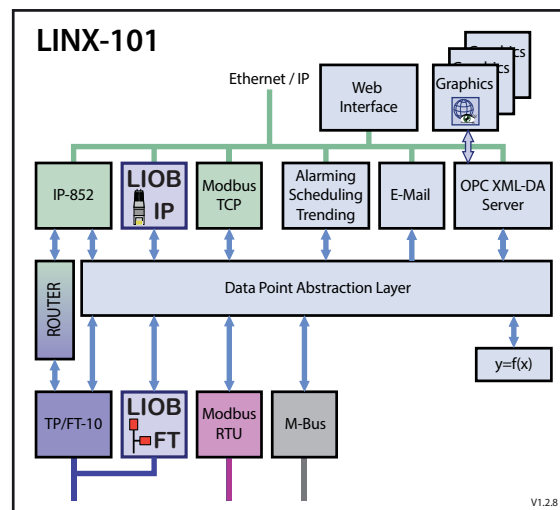
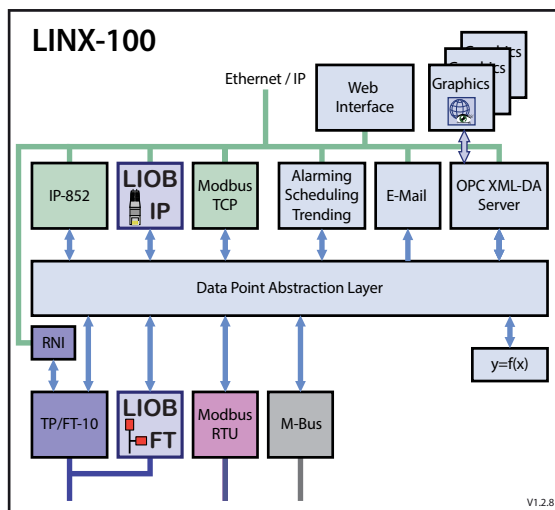

Features

- System visualization via LWEB-802/803
- Stores customized graphical pages
- Extension with physical inputs and outputs using L-IOB I/O Modules (LIOB-FT or LIOB-IP852)
- Built-in OPC XML-DA server
- Alarming, Scheduling, and Trending (AST™)
- Event-driven e-mail notification
- Compliant with CEA-709, CEA-852, and ISO/IEC 14908 standard (LonMark System)
- Supports TP/FT-10 or IP-852 (Ethernet/IP)
- Support of dynamically created or static NVs
- Support of CEA-709 user-defined NVs (UNVTs) and Configuration Properties (SCPTs, UCPTs)
- CEA-709 Remote Network Interface (RNI) with 2 MNI devices (LINX-100 only)
- Integrated IP-852 to TP/FT-10 Router (LINX-101 only)
- M-Bus Master according to EN 13757-3, connection via optional M-Bus Converter (L-MBUS20 or L-MBUS80)
- Modbus TCP and Modbus RTU (Master or Slave)
- Gateway functions including Smart Auto-Connect™
- Integrated web server for device configuration and monitoring data points
- Access to network statistics
- Configurable via Ethernet, or TP/FT-10

L-INX Automation Server

LINX-100, LINX-101

Specifications

Dimensions (mm)	107 x 100 x 60 (L x W x H), DIM009
Installation	DIN rail mounting following DIN 43880, top hat rail EN 50022
Power supply	12-35 VDC / 12-24 VAC \pm 10 %, typ. 3 W
Operating conditions	0 °C to 50 °C, 10–90 % RH @ 50 °C, non condensing, degree of protection: IP40, IP20 (terminals)
Interfaces	1 x Ethernet (100Base-T) OPC XML-DA LIOB-IP LonMark IP-852* Modbus TCP (Master or Slave) HTTP, FTP 1 x TP/FT-10* (LonMark System) 1 x Modbus RTU (Master or Slave) 1 x M-Bus (Master EN 13757-3) 1 x RS-232 (EIA-232) 1 x LIOB-FT <i>LINX-100: * Either LonMark IP-852 or TP/FT-10</i> <i>LINX-101: * Router between LonMark IP-852 and TP/FT-10</i>
L-IOB I/O Modules	Up to 8 L-IOB I/O Modules in any combination of type LIOB-FT and LIOB-IP852
Remote Network Interface	1 RNI with 2 MNI devices (LINX-100 only)
CEA-709 Router	1 (LINX-101 only)
Tools	L-INX/L-GATE Configurator

Resource limits

Total number of data points	10 000	Total trended data points	256
OPC XML-DA data points	2 000	E-mail templates	100
Network variables (NVs)	1 000	Math objects	100
Alias NVs	1 000	Alarm logs	10
External NVs (polling)	1 000	M-Bus data points	1 000
Address table entries	512 (non-ECS mode: 15)	Modbus data points	2 000
LonMark Calendars	1 (25 calendar patterns)	Connections (Local / Global)	2 000 / 250
LonMark Schedulers	100	Number of L-WEB clients	15 (simultaneously)
LonMark Alarm Servers	1	L-IOB I/O Modules	8 (LIOB-FT or LIOB-IP852)
Trend logs	256 (390 000 entries, \approx 6 MB)		

Order number Product description

LINX-100	CEA-709 Automation Server, built-in Remote Network Interface (RNI)
LINX-101	CEA-709 Automation Server, built-in IP-852 Router
LIOB-150	LIOB-FT I/O Module: 8 UI, 2 DI, 2 AO, 8 DO (4 x Relay 6 A, 4 x Triac 1 A)
LIOB-151	LIOB-FT I/O Module: 8 UI, 12 DI
LIOB-152	LIOB-FT I/O Module: 6 UI, 6 AO, 8 DO (8 x Relay 6 A)
LIOB-153	LIOB-FT I/O Module: 6 UI, 6 AO, 5 DO (4 x Relay 16 A, 1 x Relay 6 A)
LIOB-154	LIOB-FT I/O Module: 7 UI, 4 AO, 7 DO (5 x Relay 6 A, 2 x Triac 1 A), 1 Pressure Sensor
LIOB-450	LIOB-IP852 I/O Module: 8 UI, 2 DI, 2 AO, 8 DO (4 x Relay 6 A, 4 x Triac 1 A)
LIOB-451	LIOB-IP852 I/O Module: 8 UI, 12 DI
LIOB-452	LIOB-IP852 I/O Module: 6 UI, 6 AO, 8 DO (8 x Relay 6 A)
LIOB-453	LIOB-IP852 I/O Module: 6 UI, 6 AO, 5 DO (4 x Relay 16 A, 1 x Relay 6 A)
LIOB-454	LIOB-IP852 I/O Module: 7 UI, 4 AO, 7 DO (5 x Relay 6 A, 2 x Triac 1 A), 1 Pressure Sensor
LPOW-2415B	Power supply unit with power connector 24 VDC, 15 W
L-MBUS20	M-Bus level converter for 20 M-Bus devices
L-MBUS80	M-Bus level converter for 80 M-Bus devices